

## Research Article

Junita Padang<sup>1\*</sup>, Kiki Farida Ferine<sup>2</sup>

# The Influence of Work Discipline on Teacher Work Effectiveness with Organizational Commitment as an Intervening Variable in the Islamic Education Section Dairi Regency Ministry of Religion Office

\*Corresponding Author: **Junita Padang**: Universitas Pembangunan Panca Budi, Indonesia; [junitapadang@gmail.com](mailto:junitapadang@gmail.com)

**Kiki Farida Ferine**: Universitas Pembangunan Panca Budi, Indonesia; [kikifarida@dosen.pancabudi.ac.id](mailto:kikifarida@dosen.pancabudi.ac.id)

DOI: <https://doi.org/10.47353/ijedl.v1i6.73>

**Abstract:** Human Resources (HR) are a central factor in an educational institution. However, the fundamental phenomenon that currently tends to occur in educational institutions is the existence of educators and education personnel (HR) who are less qualified. National education has not been able to create superior human resources, both in terms of intellectuality, morality and spirituality. This type of research is quantitative, this research was conducted at the Dairi Regency Ministry of Religion Office, the research population was 275 and used the Slovin technique to draw samples, the samples taken were 163 employees. Data collection was carried out by distributing questionnaires and the research model used is analytical skill and smart PLS is the measuring tool. The results of this research are as follows: Work Discipline has a positive and significant effect on Teacher Work Effectiveness. Work Discipline has a positive and significant effect on Organizational Commitment. Organizational Commitment has an insignificant negative effect on Teacher Work Effectiveness. Work Discipline has a negative and insignificant effect on Teacher Work Effectiveness through Organizational Commitment.

**Keywords:** Work Discipline, Organizational Commitment, Teacher Work Effectiveness

## Introduction

Human Resources (HR) are a central factor in an educational institution. However, the fundamental phenomenon that currently tends to occur in educational institutions is the existence of educators and education personnel (HR) who are less qualified. National education has not been able to create superior human resources, both in terms of intellectuality, morality, spirituality, professionalism and national competitiveness or competitiveness. Anticipating this, HR Management must be actively involved in planning, managing and controlling the organization related to HR development. Changing a responsive work system to a proactive one, and a functional structure to a more flexible structure and implementing strategic policies. Dessler believes that human resource management is the process of acquiring, training, assessing and compensating employees, paying attention to their work relationships, health, security and justice issues. Another definition of Human Resource Management (HRM) is all

activities related to recognizing the importance of educators and education personnel in schools as vital human resources, who contribute to school goals, and utilize functions and activities that ensure that human resources utilized effectively and fairly for the benefit of individuals, schools and society.

Discipline is something that can be used as a benchmark to determine whether the role of a manager or leader as a whole can be carried out well or not. Discipline is also a form of employee self-control and regular implementation in showing the level of seriousness of employees' work in a company or organization, where employees who do not comply with the rules set by the company will receive sanctions. Therefore, this disciplinary action cannot be applied haphazardly, so it requires wise consideration. The importance of employee work discipline is one of the efforts that must be made in an agency, where with discipline it is hoped that they will have a sense of responsibility to carry out tasks, plan, organize and control the potential of human

resources and can improve employee welfare (Siswanto, 2009).

Organizational commitment is an interesting phenomenon because of the importance of a person's commitment to the company where the individual works or the organization, therefore many researchers want to research organizational commitment. According to Sianipar and Haryani (2014) organizational commitment is the attitude and feelings that each individual has towards their organization. This attitude can be seen from each individual's decision to continue or not continue their membership in the organization, and can make the best contribution to the progress of the company where they are. work wholeheartedly. Organizational commitment is a feeling of belief in the values contained in an organization, individual involvement in the interests of the organization with full effort, and loyalty to the organization (wanting to become a permanent member of the organization) which is a statement from an employee to the organization. High organizational commitment from employees will encourage employees to be responsible and provide more energy to support the success and prosperity of the company where they work. (Dewi, 2016).

Teacher work effectiveness is one of the factors that plays an important role in organizational activities which needs to be fostered and developed so that organizational goals can be achieved effectively. The organization's goals will be achieved if the organization has reliable, skilled and qualified human resources so that they can provide optimal contributions and improve work performance for the organization, society and teachers themselves. Teacher work effectiveness is a person's general attitude or condition that is positive towards organizational life, so it is clear that every leader needs to take various steps so that more and more employees feel satisfied and always enthusiastic about working, which in time will reach the level of teacher work effectiveness as expected. The phenomenon of employees or teachers who as

human resources have very low discipline so that employee performance is not good because in terms of time they are often late and at work they still do not follow the SOP for some of the employees so that there is no effectiveness in work. The employees have a commitment to the organization only a few are not fully committed to the organization.

## Literature Review

### Work Discipline

According to Siswanto (2013), the definition of work discipline is "an attitude of respect, appreciation, obedience and obedience to applicable regulations, both written and unwritten, and being able to carry them out and not avoiding receiving sanctions if he violates the duties and authority given to him. to her." According to Rivai (2017) defines "work discipline as a tool used by managers to communicate with employees so that they are willing to change behavior and as an effort to increase a person's awareness and willingness to comply with all company regulations."

### Work Discipline Indicators

Basically, according to Siswanto (2013), there are many indicators of the level of employee discipline in an organization, namely:

1. Frequency
  - a. Employee attendance on time at work
  - b. Absence
2. Level of Employee Vigilance
  - a. Accuracy
  - b. Calculation
3. Adherence to Work Standards
  - a. Comply with work guidelines
  - b. Responsibility
4. Compliance with Work Regulations
  - a. Obedience
5. Work Ethics
  - a. Harmonious atmosphere
  - b. Mutual respect

## Effectiveness

According to Sedarmayanti (2017), effectiveness is a measure that provides an idea of how far the target can be achieved. This understanding of effectiveness is more output-oriented while the problem of using input is less of a main concern. According to Admosoeprapto (2016), work effectiveness is a measure that describes the extent to which targets can be achieved by employees based on the targets or standards set by the company.

## Effectiveness Indicators

According to Admosoeprapto (2016), benchmarks that can be used as indicators of work effectiveness are as follows:

1. Achievement of objectives
2. Work quality
3. Work Quantity
4. On time
5. Job satisfaction

## Organizational Commitment

According to Kreitner & Kinicki (2014) organizational commitment reflects the level to which a person knows the company and is committed to its goals. According to Wibowo (2016) organizational commitment is the feelings, attitudes and behavior of individuals identifying themselves as part of the organization, being involved in the process of organizational activities and being loyal to the organization in achieving organizational goals.

## Organizational Commitment Indicators

According to Kreitner and Kinicki (2014) there are three indicators of organizational commitment, namely:

1. Affective Commitment
2. Continuous Commitment
3. Normative Commitment

## Method

The type of research that will be used is quantitative associative, namely research that aims to determine the relationship between two or

more variables (Sugiyono, 2017). In this research, the exogenous variable is Work Discipline (X). Meanwhile, the endogenous variable is Effectiveness (Y) and the Intervening Variable is the Results of Organizational Commitment (Z).

This research was carried out at the Islamic Education Section of the Dairi Regency Ministry of Religion Office. The time this research was carried out was from March 2023 to July 2023. According to Sugiyono (2017) population is a generalized area consisting of objects/subjects that have certain qualities and characteristics determined by the researcher to be studied and then the conclusion drawn is that the population used is ASN employees 195 and non-ASN 80 total employees numbering 275.

According to Sugiyono (2017), the sample is part of the number and characteristics of the population. If the population is large, and it is impossible for researchers to study everything in the population, for example due to limited funds, energy and time, then researchers can use samples taken from that population. The sampling technique used is slovin to reduce too large a population.

$$n = N / (1 + (N \times e^2))$$

$$n = 275 / (1 + (275 \times 0.0025))$$

$$n = 275 / (1 + 0.687)$$

$$n = 275 / 1,687$$

$$n = 163,011$$

The results will be rounded to 163, meaning the sample that will be used is 163 employees.

The data analysis technique used in this research is a quantitative data analysis method. Data analysis in this research uses Structural Equation Modeling (SEM) based on Partial Least Square (PLS) using SmartPLS 3.3.3 software which is run on a computer.

## Measurement Model (Outer Model)

The procedure for testing the measurement model consists of a validity test and a reliability test.

### 1. Validity Test

The validity test is used to assess whether a questionnaire is valid or not. A questionnaire is said to be valid if the

questionnaire questions are able to reveal something that is measured by the questionnaire. Validity testing is applied to all question items for each variable.

## 2. Reliability Test

In general, reliability is defined as a series of tests to assess the reliability of statement items. Reliability testing is used to measure the consistency of measuring instruments in measuring a concept or measure the consistency of respondents in answering statement items in questionnaires or research instruments. To measure the level of reliability of research variables in PLS, you can use the alpha coefficient value or Cronbach's alpha and composite reliability). Cronbach's alpha value is recommended to be greater than 0.7 and composite reliability is also recommended to be greater than 0.7. (Sekaran, 2014)

### **Structural Model (Inner Model)**

This test was carried out to determine the relationship between exogenous and endogenous constructs which have been hypothesized in this research (Hair et al., 2017). To produce inner model test values, the steps in SmartPLS are carried out using the bootstrapping method. The structural model was evaluated using R-square for the dependent variable, Stone-Geisser Q-square test for predictive elevation and t test as well as the significance of the structural path parameter coefficients with the following explanation:

#### 1. Coefficient of Determination / R Square (R<sup>2</sup>)

In assessing the model with PLS, start by looking at the R-square for each dependent latent variable. The interpretation is the same as the interpretation of regression. Changes in the R-square value can be used to assess the influence of certain independent latent variables on the dependent latent variable whether they have a substantive influence (Ghozali, 2012). The R<sup>2</sup> value is generally between 0 and 1.

#### 2. Predictive Relevance (Q<sup>2</sup>)

This test is used to measure how well the observation values are produced by the model and

also the estimated parameters. If the Q<sup>2</sup> value is greater than 0, it indicates the model has predictive relevance, which means it has good observation value, whereas if the value is less than 0, it indicates the model does not have predictive relevance (Ghozali, 2014).

#### 3. t-Statistics

At this stage it is used for hypothesis testing, namely to determine the significance of the relationship between variables in the research using the bootstrapping method. In the full model, Structural Equation Modeling, apart from confirming the theory, also explains whether or not there is a relationship between latent variables (Ghozali, 2012). The hypothesis is said to be accepted if the statistical t value is greater than the t table. According to (Latan and Ghozali, 2012) the t table value criteria is 1.96 with a significance level of 5%

#### 4. Path Coefficient

This test is used to determine the direction of the relationship between variables (positive/negative). If the value is 0 to 1, then the direction of the relationship between variables is declared positive. Meanwhile, if the value is 0 to -1, then the direction of the relationship between the variables is declared negative.

#### 5. Fit Model

This test is used to determine the level of suitability (fit) of the research model with the ideal model for this research, by looking at the NFI value in the program. If the value is closer to 1, the better (good fit).

## **Results and Discussion**

### **Outer Model Analysis**

In testing the outer model, the aim is to see the validity and reliability of a model. This test analysis will look at the influence of the Loading factor, Average Variance Extracted (AVE), and Discriminant Validity, as well as composite reliability.

#### **a) Loading factor**

Factor loading is the initial stage in testing the validity of a model, the condition for factor loading is that it must be > 0.6, so that the indicator is said to be valid. If it is not valid then

it must be removed from the model (Husein. 2015). To find out the outer model analysis for this research, you can see the image below:

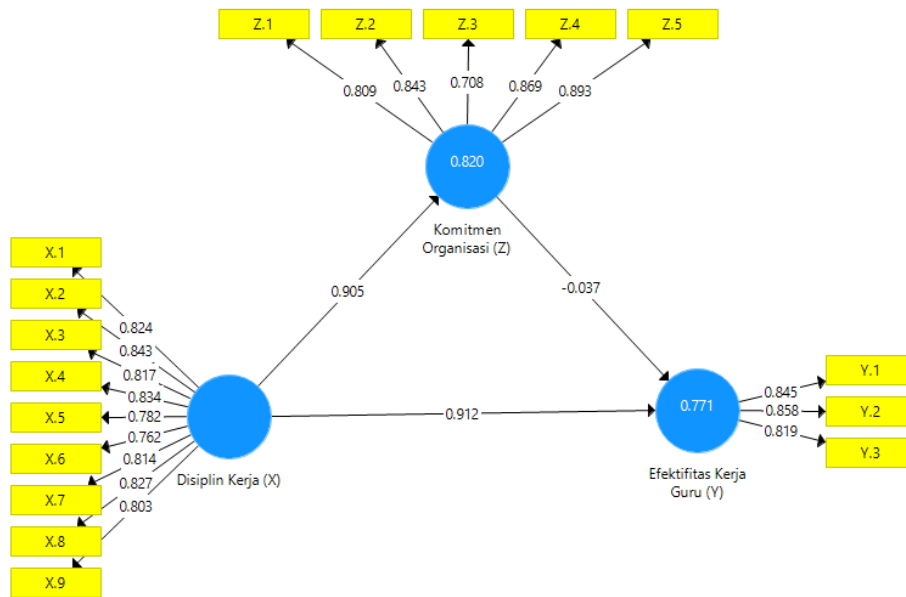

Figure 1. Outer Model  
Source: Smart PLS 3.3

If you look at the figure above, it can be seen that in the latent variable for each variable, the loading factor value for each manifest variable is greater with a value of 0.7, which means that all indicators and loading factors have valid distributions. The regression equation from this research is as follows:  
substructure 1:

$$Z = b_1X_1 + e_1$$

$$Z = 0.905X_1 + e_1$$

For substructure 2:

$$Y = b_3X_1 + b_5Z + e_2$$

$$Y = 0.912X_1 - 0.037X_2 + e_2$$

Table 1. Outer Loadings

	Work Discipline (X)	Teacher Work Effectiveness (Y)	Organizational Commitment (Z)
X.1	0.824		
X.2	0.843		
X.3	0.817		
X.4	0.834		
X.5	0.782		
X.6	0.762		
X.7	0.814		
X.8	0.827		
X.9	0.803		
Y.1		0.845	
Y.2		0.858	
Y.3		0.819	

Z.1			0.809
Z.2			0.843
Z.3			0.708
Z.4			0.869
Z.5			0.893

Source: Smart PLS 3.3

Based on table 1 above, it shows that all loading factor values are above 0.50. It can be concluded that the reflective indicators used in this research are valid or have met the requirements of the convergent validity test, which means that the research instrument items (questionnaire) can accurately measure the reflective variables in this research.

**Discriminate Validity**

Apart from that, there is a discriminant validity test which can be seen from the Fornell-Lacker Criterium value and the AVE value of each statement instrument on the reflective indicators in this study. Where these two tables are used to ensure that the variables in this research are valid.

**Table 2. Discriminant Validity**

	Work Discipline (X)	Teacher Work Effectiveness (Y)	Organizational Commitment (Z)
X.1	0.824	0.718	0.823
X.2	<b>0.843</b>	0.661	0.824
X.3	0.817	0.654	0.727
X.4	0.834	0.741	0.697
X.5	0.782	0.797	0.662
X.6	0.762	0.745	0.639
X.7	0.814	0.688	0.745
X.8	0.827	0.731	0.779
X.9	0.803	0.683	0.708
Y.1	0.733	<b>0.845</b>	0.671
Y.2	0.747	<b>0.858</b>	0.653
Y.3	0.734	0.819	0.664
Z.1	0.772	0.682	0.809
Z.2	0.782	0.687	0.843
Z.3	0.587	0.473	0.708
Z.4	0.757	0.646	0.869
Z.5	0.818	0.734	<b>0.893</b>

Source: Smart PLS 3.3.3

It can be seen in the results of table 2 above that the cross loading value of each variable has a cross loading value that is greater than the other latent variables so it can be concluded that this research is considered discriminantly valid.

**3. Composite reliability**

In composite reliability research to look at each variable with its reliability value and if the variable value is greater than 0.60 then the research is considered reliable and if it is below 0.60 and 0.7 then it is not reliable. There are several blocks to determine whether the research is reliable or not and valid or not, including the

Coranbach alpha value, composite reliability and AVE value can be seen in the table below:

**Table 3. Construct Reliability and Validity**

	Cronbach's Alpha	Composite Reliability	Average Variance Extracted (AVE)
Work Discipline (X)	0.935	0.946	0.660
Teacher Work Effectiveness (Y)	0.793	0.879	0.707
Organizational Commitment (Z)	0.883	0.915	0.684

Source: Smart PLS 3.3.3

In table 3 above, it can be seen in the Cronbach alpha column that the value for each variable is greater than 0.7, which means that the reliability data is reliable for the variable. The composite reliability column has a value greater than 0.6 so it can be explained that each variable is considered reliable because the data is greater than 0.6. You can see from the AVE column that each variable has a value greater than 0.7, which means the data is valid in AVE terms. All variables from the Cronbach alpha column, reliability column and AVE column have values greater than 0.7 and 0.6 so they are considered reliable and valid.

### Inner Model Analysis

Evaluation of the structural model (inner model) is carried out to ensure that the basic model created is strong and correct. The inspection stages carried out in the primary model assessment can be seen from several markers, namely:

### Coefficient of Determination (R<sup>2</sup>)

The R square test is used for the dependent variable to measure how far the model's ability is to explain variations in the dependent variable. (Ghozali, 2014). The SmartPLS 3.0 software output results regarding R square are as follows:

**Table 4. R Square Results**

	R Square	Adjusted R Square
Teacher Work Effectiveness (Y)	0.771	0.768
Organizational Commitment (Z)	0.820	0.818

Source: Smart PLS 3.3.3

In the R square results, the Teacher Work Effectiveness variable is 0.771 and the percentage is 77.1%, meaning that the influence of the Work Discipline and Organizational Commitment variables on Teacher Work Effectiveness is 77.1% and the rest are other variables. The R square value of the Organizational Commitment variable is 0.820 and the percentage is 82.0%, meaning that the influence of the Work Discipline variable on Organizational Commitment is 82.0% in other variables.

### Hypothesis test

After assessing the inner model, the next thing is to assess the connection between the idle builds as suspected in this review. Speculation testing in this review was carried out by looking at T-Statistics and P-Values. Speculation was announced admitting whether T-Insights values > 1.96 and P-Values < 0.05. Next are the consequences of the direct impact Path Coefficient:

**Table 5. Path Coefficients (Direct Influence) and Path Coefficients (Indirect Influence)**

	Original Sample (O)	T Statistics (  O/STDEV  )	P Values	Results
Work Discipline (X) -> Teacher Work Effectiveness (Y)	0.912	7,382	0,000	Accepted
Work Discipline (X) -> Organizational Commitment (Z)	0.905	59,178	0,000	Accepted
Organizational Commitment (Z) -> Teacher Work Effectiveness (Y)	-0.037	0.282	0.778	Rejected
Work Discipline (X) -> Organizational Commitment (Z) -> Teacher Work Effectiveness (Y)	-0.034	0.281	0.779	Rejected

Source: Smart PLS 3.3.3

Based on the results of the hypothesis above, there is the following explanation:

1. Work Discipline has a positive and significant effect on Teacher Work Effectiveness with an original sample value of 0.912 and a P value of 0.000, meaning that if work discipline increases, effectiveness increases and if work discipline decreases, work effectiveness decreases.
2. Work Discipline has a positive and significant effect on Organizational Commitment with an original sample value of 0.905 and a P value of 0.000, meaning that if work discipline increases, organizational commitment will increase and if it decreases, organizational commitment will also decrease.
3. Organizational Commitment has an insignificant negative effect on Teacher Work Effectiveness with an original sample value of -0.037 and a P value of 0.778, meaning there is no influence of organizational commitment on Teacher Work Effectiveness because commitment to the organization does not necessarily mean that teachers will be effective at work.
4. Work Discipline has a negative and insignificant effect on Teacher Work Effectiveness through Organizational Commitment with an original sample value of -0.034 and a P value of 0.779, meaning that Organizational Commitment is not an

intervening variable because it is unable to have a significant indirect influence.

## Closing

### Conclusion

1. Work Discipline has a positive and significant effect on Teacher Work Effectiveness in the Section
2. Islamic Education Dairi Regency Ministry of Religion Office.
3. Work Discipline has a positive and significant effect on Organizational Commitment in the Islamic Education Section of the Dairi Regency Ministry of Religion Office.
4. Organizational Commitment has an insignificant negative effect on Teacher Work Effectiveness in the Islamic Education Section of the Dairi Regency Ministry of Religion Office.
5. Work Discipline has a negative and insignificant effect on Teacher Work Effectiveness through Organizational Commitment in the Islamic Education Section of the Dairi Regency Ministry of Religion Office.

### Suggestion

1. Organizations must be able to create better discipline to create better employee performance and be able to correct mistakes quickly.



2. Organizations must have teachers who prioritize good performance and increase work effectiveness and are very focused.
3. After improving performance well, teachers must instill commitment to their organization so that teacher performance improves well.

## References

- Admosoeprapto, K. (2016). *Produktivitas Aktualisasi Budaya Perusahaan*. Jakarta: Gramedia.
- Dewi, N. L. Y. A., & Suwanda, I. G. M. (2016). Pengaruh Kepuasan Kerja terhadap Organizational Citizenship Behavior (OCB) dengan Komitmen organisasional Sebagai Variabel Mediasi. vol.5(No.9).
- Ghozali, Imam. (2014). *Structural Equation Modeling Metode Alternatif dengan Partial Least Square (PLS) Edisi 4*. Universitas Diponegoro, Semarang.
- Hair, J. F. et. al. 2017. *A Primer on Partial Least Squares Structural Equation Modeling (PLS-SEM)*. SAGE Publications, Los Angeles.
- Herminingsih, D. I., & Isro'iyah, L. (2023). The Metadiscourse Analysis in Abstracts of Multidisciplinary Sciences Journal Articles: Hedges vs Boosters. *International Linguistics Research*, 6(1), p24-p24.
- Isro'iyah, L., & Herminingsih, D. I. (2023). Teaching Culture of Others through English Literature: English. *International Journal of Language and Literary Studies*, 5(2), 136-146.
- Kreitner, Robert dan Angelo Kinicki. 2014. *Perilaku Organisasi*. Edisi 9. Buku 1. Jakarta: Salemba Empat.
- Rivai, Veithzal. 2017. *Manajemen Sumber Daya Manusia Untuk Perusahaan Dari Teori ke Praktik*. Jakarta: Rajawali Press.
- Sedarmayanti. (2017). *Manajemen Sumber daya Manusia, Reformasi Birokrasi dan Manajemen Pegawai Negeri Sipil*. Bandung: Refika Aditama
- Sekaran, Uma. 2014. *Metodologi Penelitian Untuk Bisnis (Research Methods for Business) Buku 1 Edisi 4*. Jakarta: Salemba Empat.
- Sianipar, A.R.B. dan Haryanti, K. 2014. Hubungan Komitmen Organisasi dan Kepuasan Kerja dengan Intensi Turnover pada Karyawan Bidang Produksi CV. X. *Jurnal Psikodemensia*. Vol. XIII, No.1 (98-114).
- Siswanto, (2013), *Pengantar Manajemen*. Jakarta: Bumi Aksara
- Sugiyono. (2017). *Metode Penelitian Kuantitatif, Kualitatif, dan R&D*. Bandung: Alfabeta, CV.
- Wibowo, 2016. *Manajemen Kinerja*, Edisi Kelima, PT. Rajagrafindo Persada Jakarta-14240.

